

A *FleetWatch* INITIATIVE

# LIGHT UP THAT TRUCK

## Do it the right way

**Truck visibility is an essential safety factor including not only front and rear tail lights and indicators, but the high visibility reflective tape on the sides and rear of trucks and trailers. The need to apply correctly, keep clean and replace regularly is crucial... read on and do it right.**

### Applications on different vehicle types

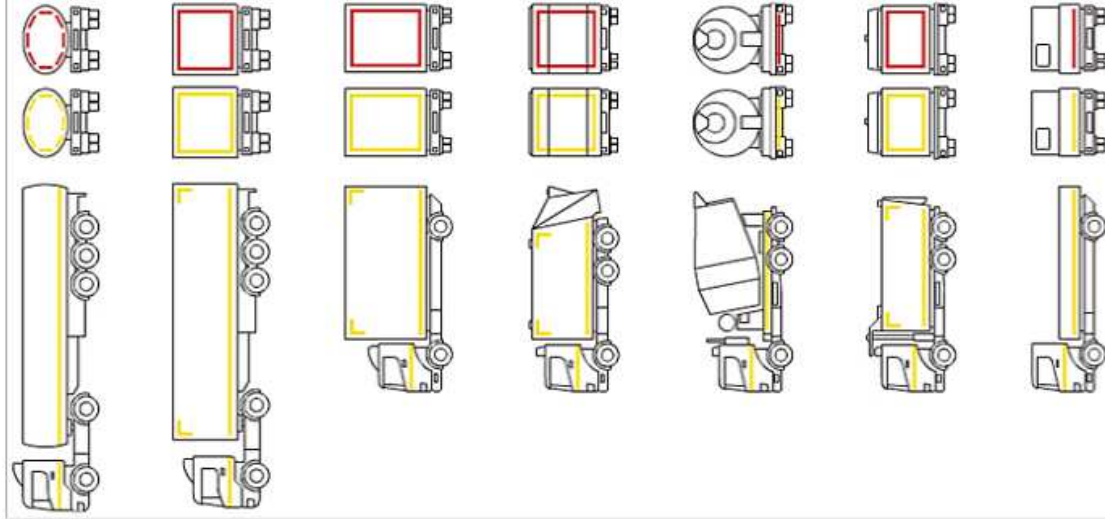

### Where should the tapes be applied?

**To the rear:** Here a full contour marking is required, i.e. a full 'box'.

**To the sides:** Here you can choose to do either a full contour ('box') marking, or a linemarking of the length of the vehicles plus marking of the upper corners if the design of the vehicles allows for this. It is a good idea to mark also the tractor (e.g. on the door) to visually get a marking of the full length of the vehicles, however this is not an obligation. Minimum 80% of the length of the vehicle (excl. the length of the cabin) must be marked. The lower line of the marking tape must be placed minimum 25cm from the ground, and in a height of maximum 150cm. This can in special cases be extended to 250cm.

The length of the upper corner markings must be minimum 25cm. Upper corner markings should be applied as high as practical, but within 40cm of the upper extremity of the vehicle. In cases where a top corner marking is not possible due to the construction of the vehicle, a line marking on its own is allowed.

### SABS Certified for ECE 104 CLASS C / R.48-03 Application Guidelines

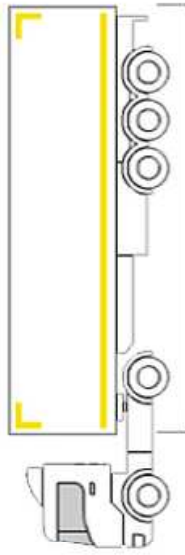

Minimum 80%  
\*Down to 60% or 40% for difficult applications)

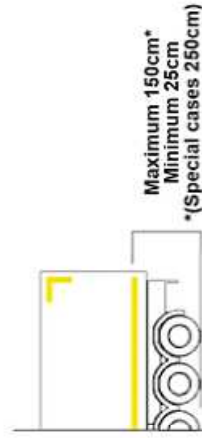

CONTACT NUMBER

Tel: 011-394 7783

E-mail: [orafol.sa@orafol.com](mailto:orafol.sa@orafol.com)

Website: [www.orafol.com](http://www.orafol.com)

**ORAFOL®**

**Reflexite®**